

Ingersoll
T-Cap
multifunction tool
handles turning, facing,
drilling, and boring on
BVR Technologies'
carrier part, boosting
throughput by two
thirds.



TRIPLE-THREAT TOOLING

Innovative tooling can have a dramatic effect on reducing setup and cycle times while improving tool life and part quality. For instance, with a new multifunctional tool from Ingersoll Cutting Tools, Rockford, Ill., one company reduced cutting times by 40% on the first day the new tool went to work.

Manufacturing engineers at BVR Technologies, a Rockford manufacturer of motion-control products, realized the process of machining a high-demand standard carrier, part of a gear assembly, was inefficient and in dire need of upgrading. Also, the carrier operation shares the same basic processing as many other BVR products. When Doug Dusing, manufacturing engineer, sought the help of Ingersoll's Mike Crabtree, he introduced Dusing to the company's new

*Multifunctional tool slashes
cutting time by 40%.*

BY JAMES BENES, ASSOCIATE EDITOR

T-Cap combination tool system. With T-Cap, a single tool turns/faces, drills, and bores. A series of tests at Ingersoll showed the system significantly reduces cutting cycle times and reduces multiple tools and inserts required when working with small components. The company reports T-Cap tooling produces hole deviations less than half that of competing

combination tools with surface finishes twice as good. And it says tool life in steel is three times better for drilling and chamfering, twice as long for turning, and better for stainless steel and grey iron.

BVR machined the 1.5-in. diameter \times 0.25-in.-thick carrier in an eight-step sequence using six different conventional turning tools on a nine-yr old Hardinge T42 Conquest. Cycle time was 1 min and 40 sec.

After setting up at 10 a.m. with T-Cap tooling, by 3 p.m. that same afternoon the piece was produced in just three steps, in one minute flat — 40% faster than before. Future jobs will result in even more savings because of reduced setup times. Rick Ruppert, BVR

Different edge geometries on the same T-Cap insert enable it to handle drilling and turn/bore operations.

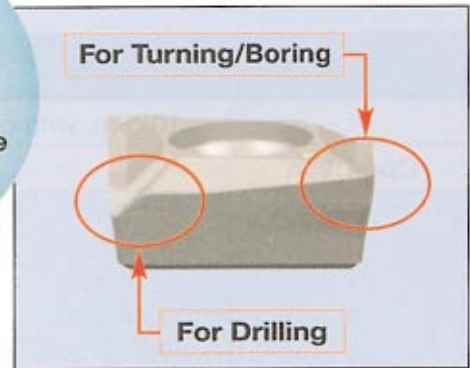

vice president/general manager, notes, "Only having to set two tools in the turret, rather than six, exerts a lot of leverage in an operation like ours."

The T-Cap combination tool looks like an indexable drill with just one insert on its face, rather than the usual two. Geometry of the insert enables drilling from solid, boring, turning, and facing. The entire front face is a cutting edge for drilling, and the outside corner works like a conventional turning and facing edge. Chipbreakers on both sides of the cutting edge deliver good chip control in both the drilling and turning/facing modes. And to save setup time still further, the optional T-Cap

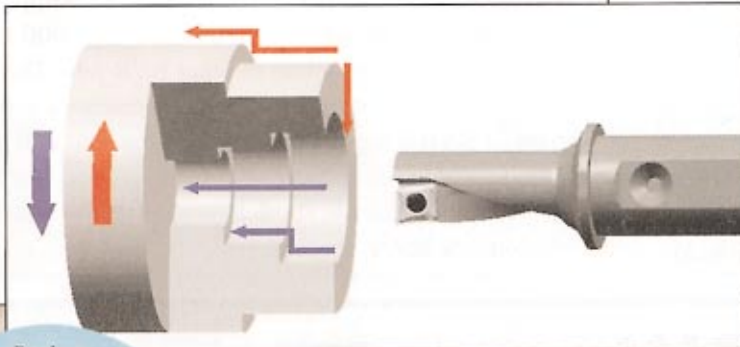

Boring with the same tool that drills the center hole. With spindle direction reversed, Ingersoll T-Cap multifunction tool then turns the OD.

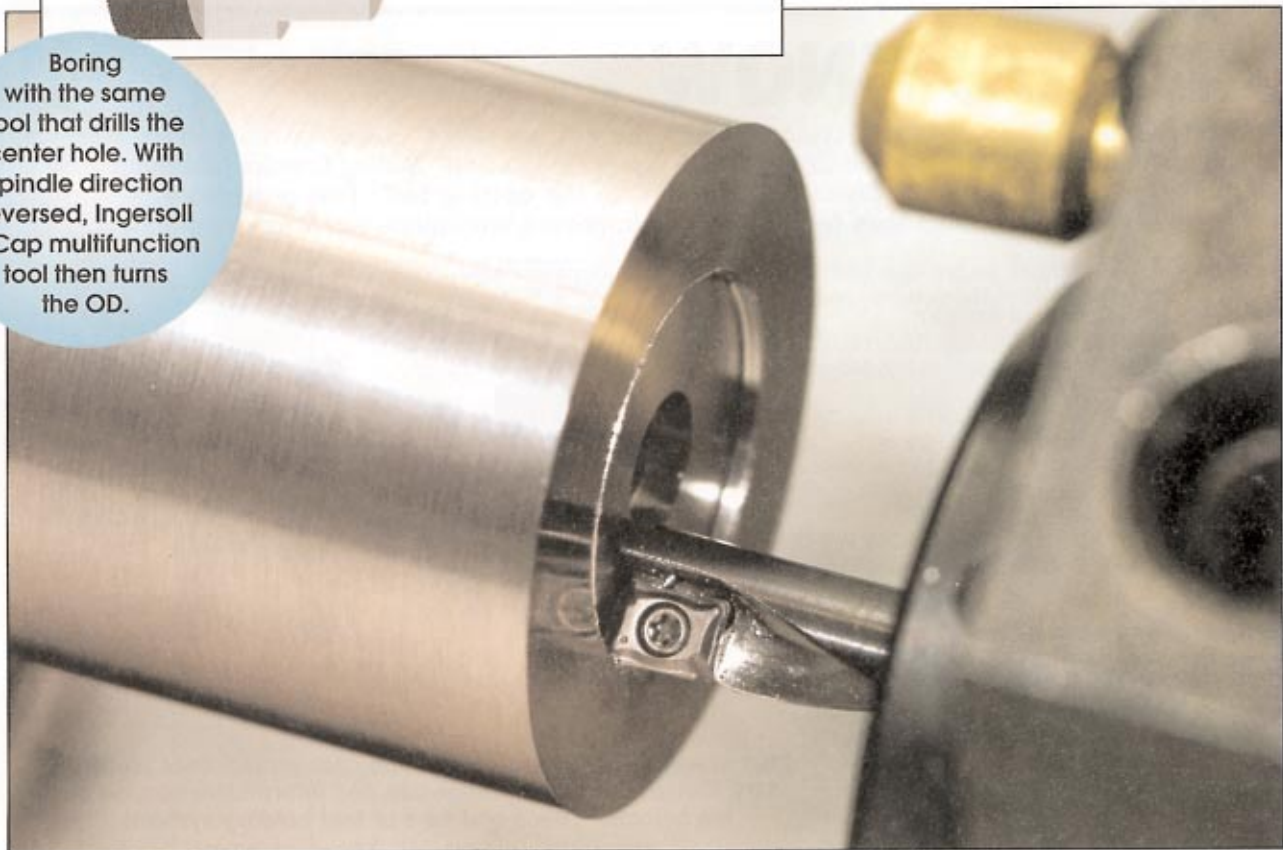

Improvement in cycle time				
Operation	10 a.m. with conventional tooling		3 p.m. with T-Cap	
	1	Bar pull	8 sec	Bar pull
2	Rough turn	10 sec	Drill, bore, turn	32 sec
3	Finish turn	8 sec	Part off	20 sec
4	Spot drill	6 sec		
5	Drill	8 sec		
6	Endmill counterbore	27 sec		
7	Finish bore	13 sec		
8	Part off	20 sec		
Total:		100 sec		60 sec

clamping unit sports a built-in center-height adjustment.

BVR engineers, together with Ingersoll's Technology Center, continued to tweak and optimize the operation. Now, parts are run from a prehardened 32 Rc material eliminating a heat-treating step. With the T-Cap tool, BVR bores and drills at 295 sfm at 0.002 ipm and turns and faces at 590 sfm at 0.003 ipm.

Because the T-Cap tool is suited to other BVR work,

Dusing leaves it in the turret for other jobs. This is projected to save at least 16 man hr/year. Ruppert estimates an annual saving of over \$10,000 by applying the T-Cap tooling to other BVR jobs. Drilling, turning and boring small parts represents a hefty share of BVR's machining work, so the tool will be busy on a lot of jobs. "More important, we'll be able to deliver sooner, handle shorter runs more efficiently, and compete better," he says. [CT](#)